

**OBSERVATIONAL  
MEDICAL  
OUTCOMES  
PARTNERSHIP**

Applying the OMOP common data model  
across administrative claims and electronic  
health records

Patrick Ryan  
on behalf of OMOP research team  
April 12, 2010

# Outstanding questions for active surveillance

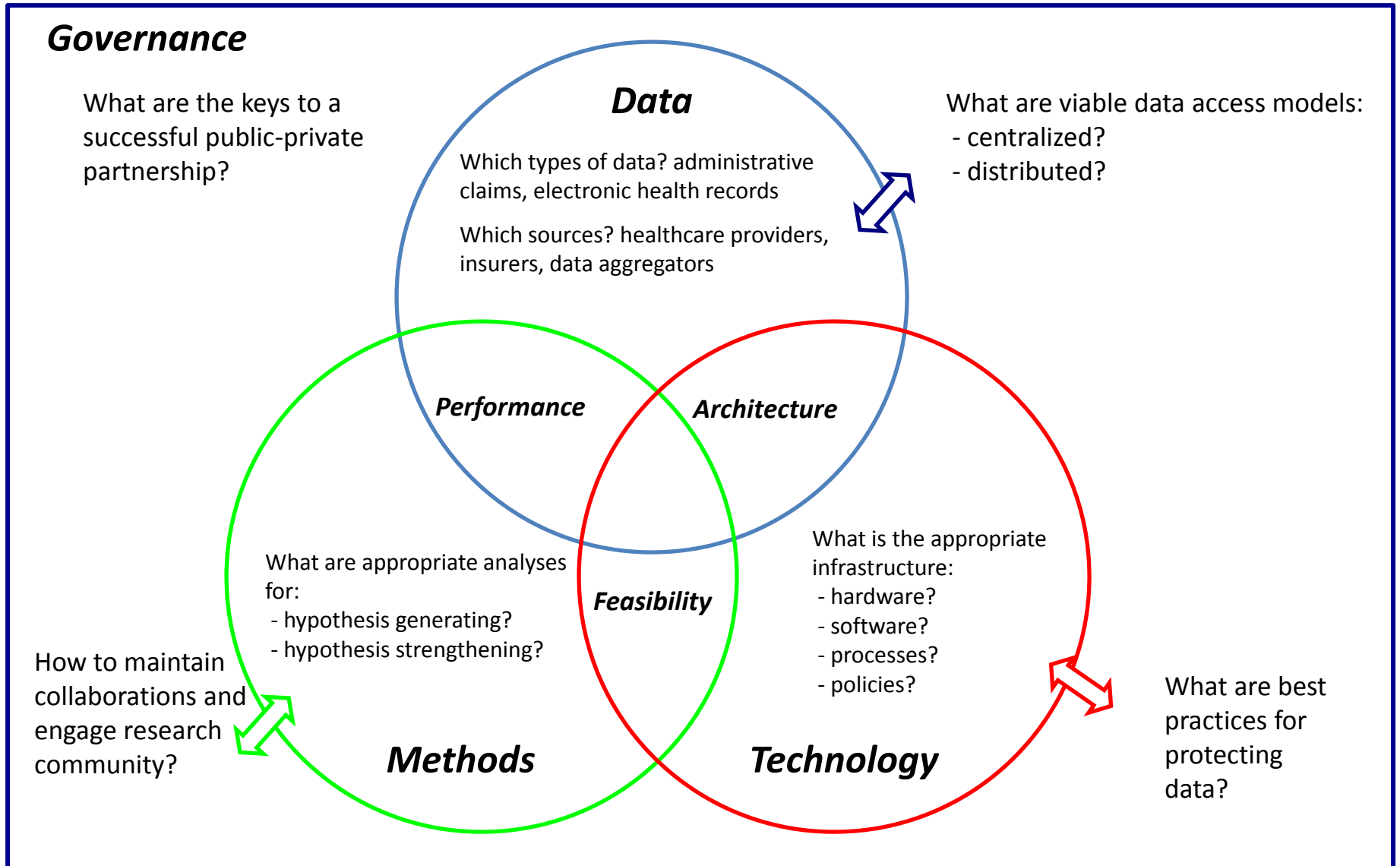

# Disparate data across OMOP community

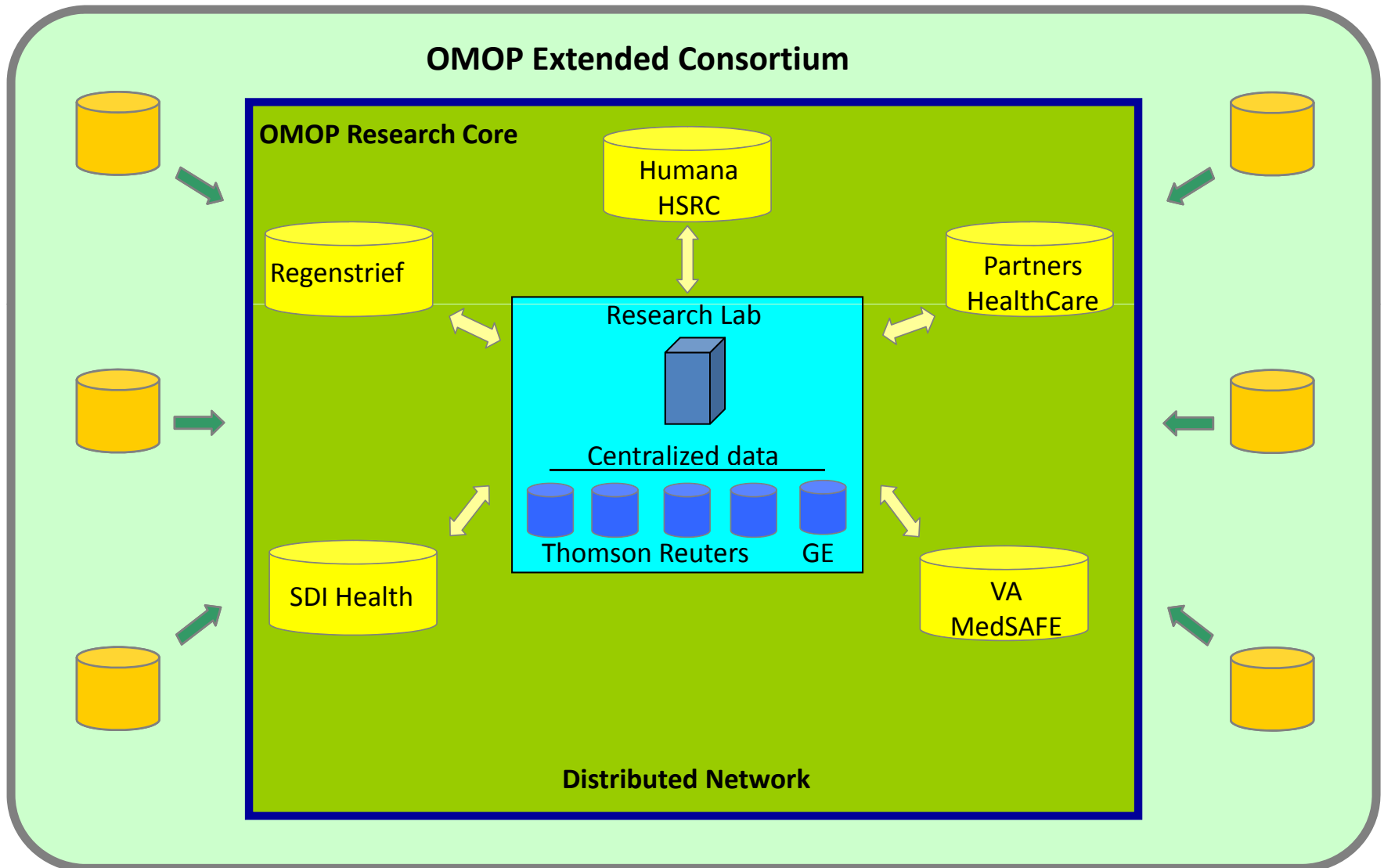

# Role of common data model in OMOP Analysis process

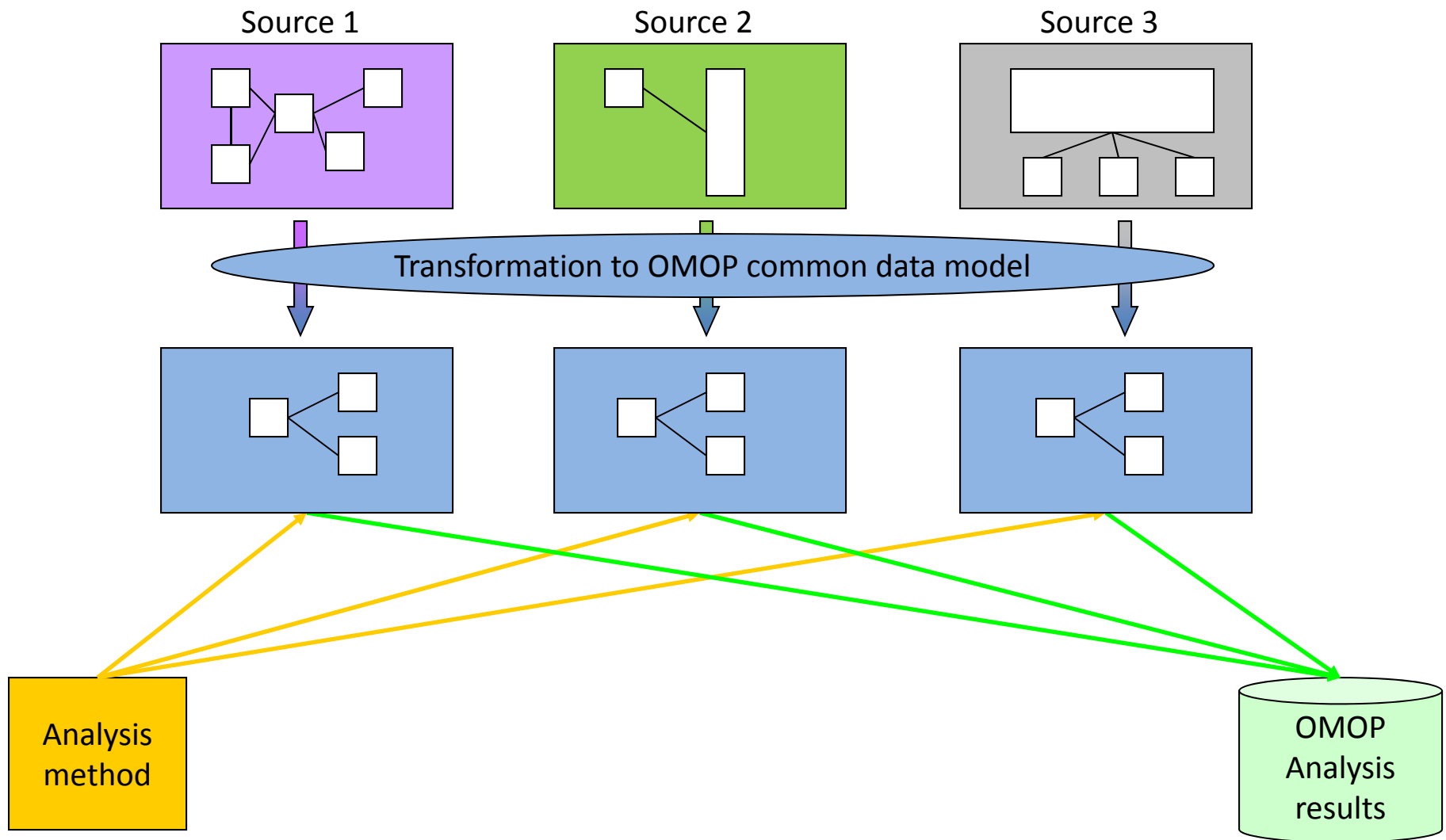

# Common Data Model

- The common data model includes:
  - A single data schema that can be applied to disparate data types
  - Standardized terminologies
  - Consistent transformation for key data elements
- A common data model can:
  - Enable consistent and systematic application of analysis methods to produce comparable results across sources
  - Create a community to facilitate the sharing of tools and practices
  - Impose data quality standards
  - Create implementation efficiencies

Common Data Model	
What We Are Doing	What We Are Not Doing
<ul style="list-style-type: none"> <li>• Creating one model that could accommodate any relevant type of observational data</li> <li>• Facilitating comparison of analysis results across sources</li> <li>• Providing a conceptual model to allow researchers to develop analysis methods that are be portable across data sources</li> </ul>	<ul style="list-style-type: none"> <li>• Combining multiple datasets into one centralized database</li> <li>• Trying to force claims data into a EHR model or vice versa</li> <li>• Developing a graphical user interface to automatically create structured queries</li> </ul>

# Establishing a common data model

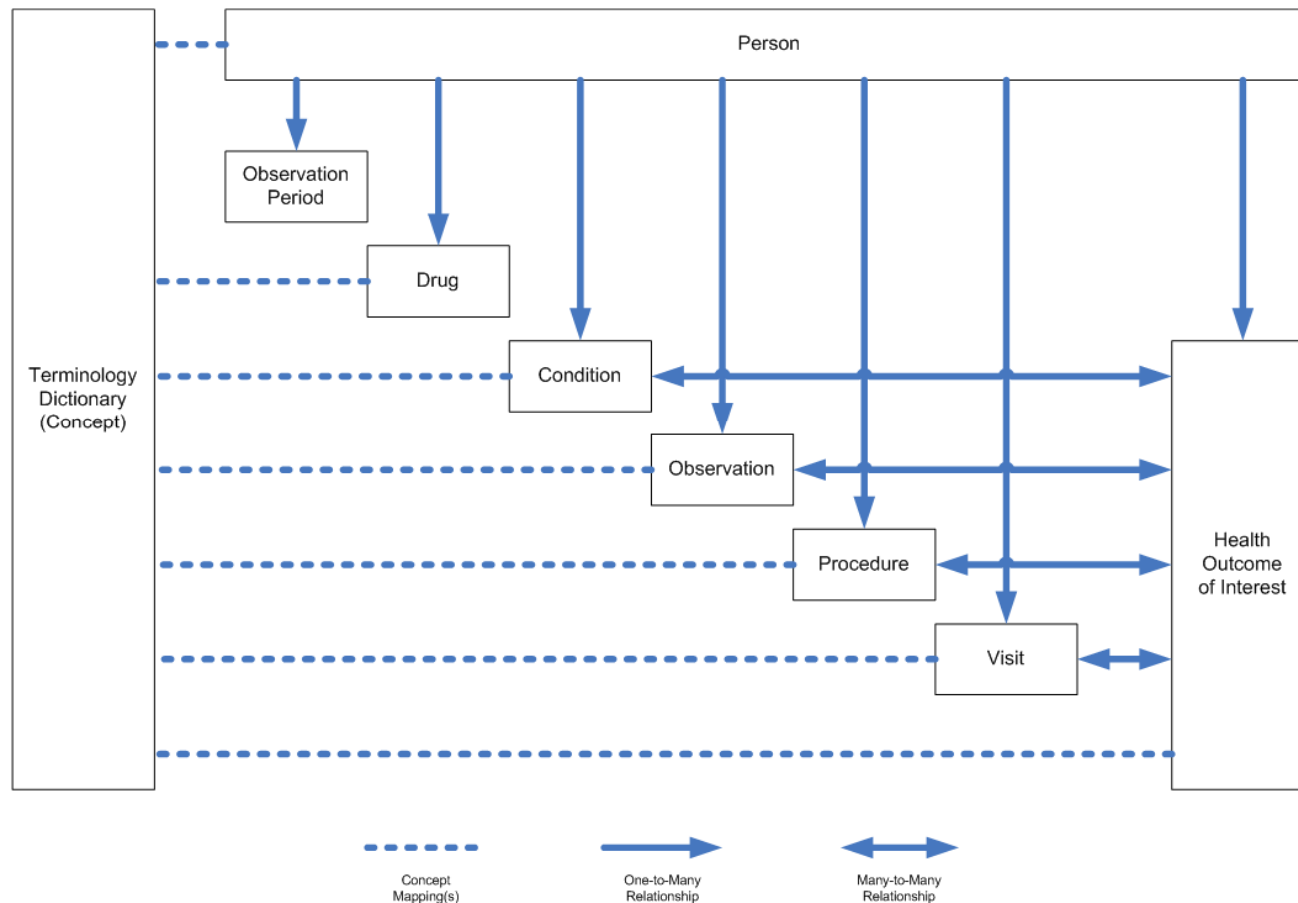

- Developed with broad stakeholder input
- Designed to accommodate disparate types of data (claims and EHRs)
- Applied successfully across OMOP data community

# Common Data Model ER diagram

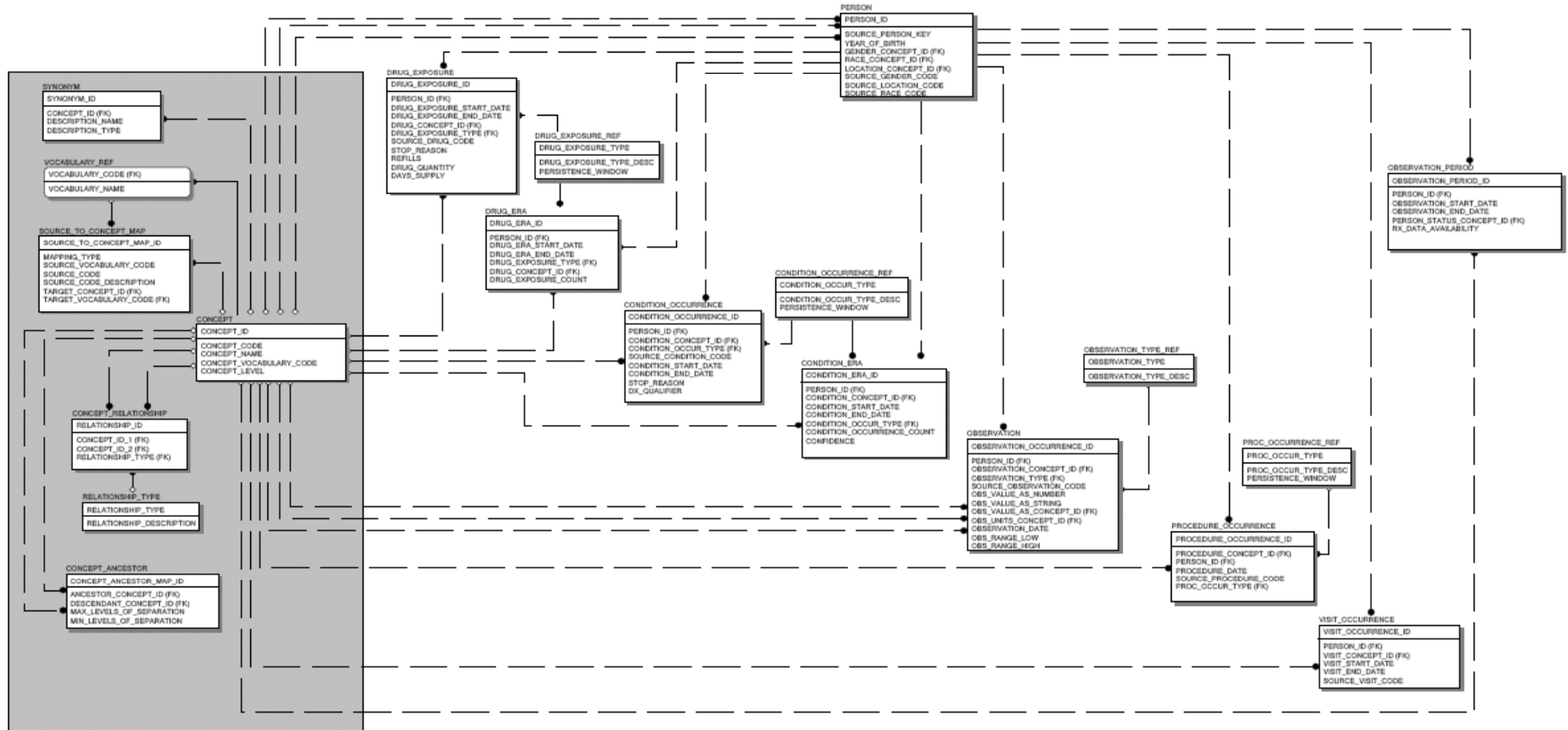

# Standardizing terminologies to accommodate disparate observational data sources

Standardizing conditions:

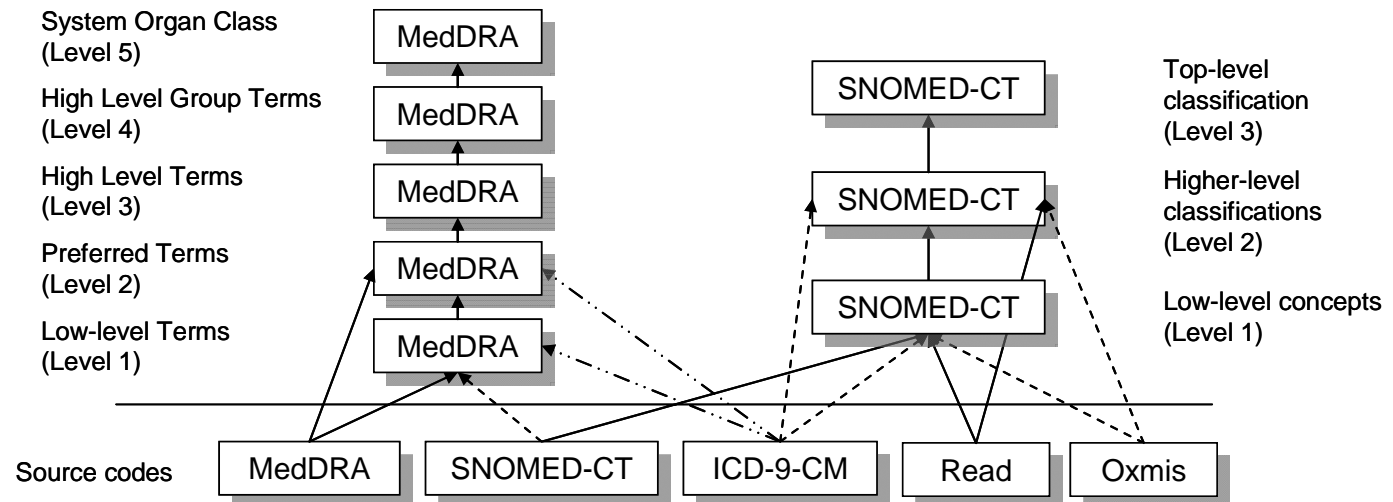

Standardizing drugs:

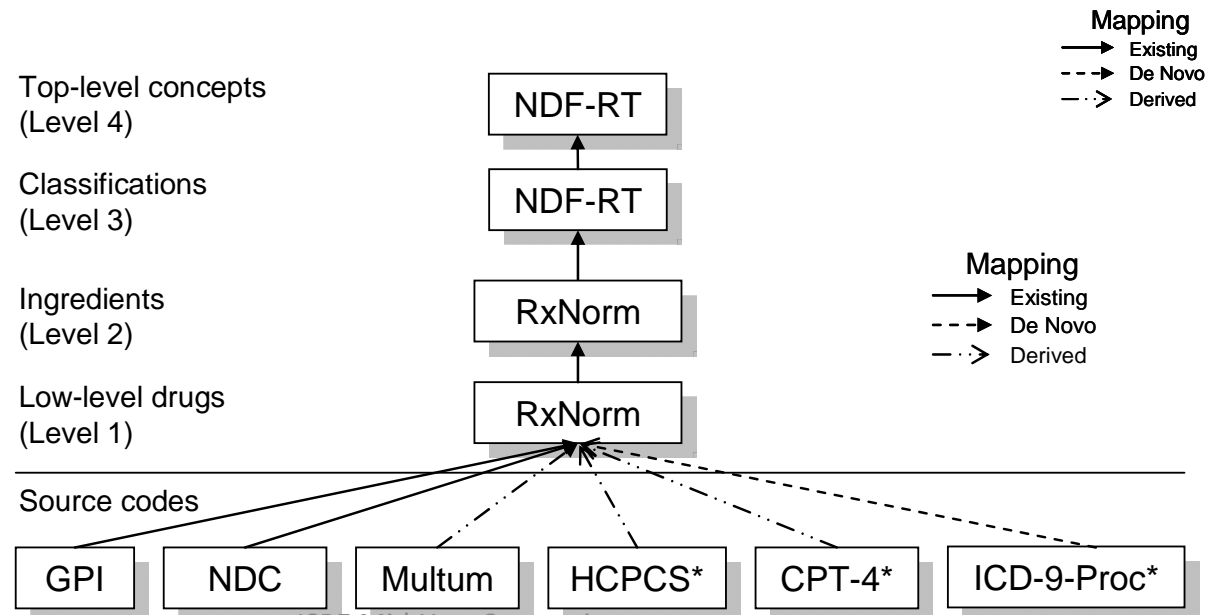

# Constructing drug and condition eras

## Using Observational Data: A single patient example Person Timeline

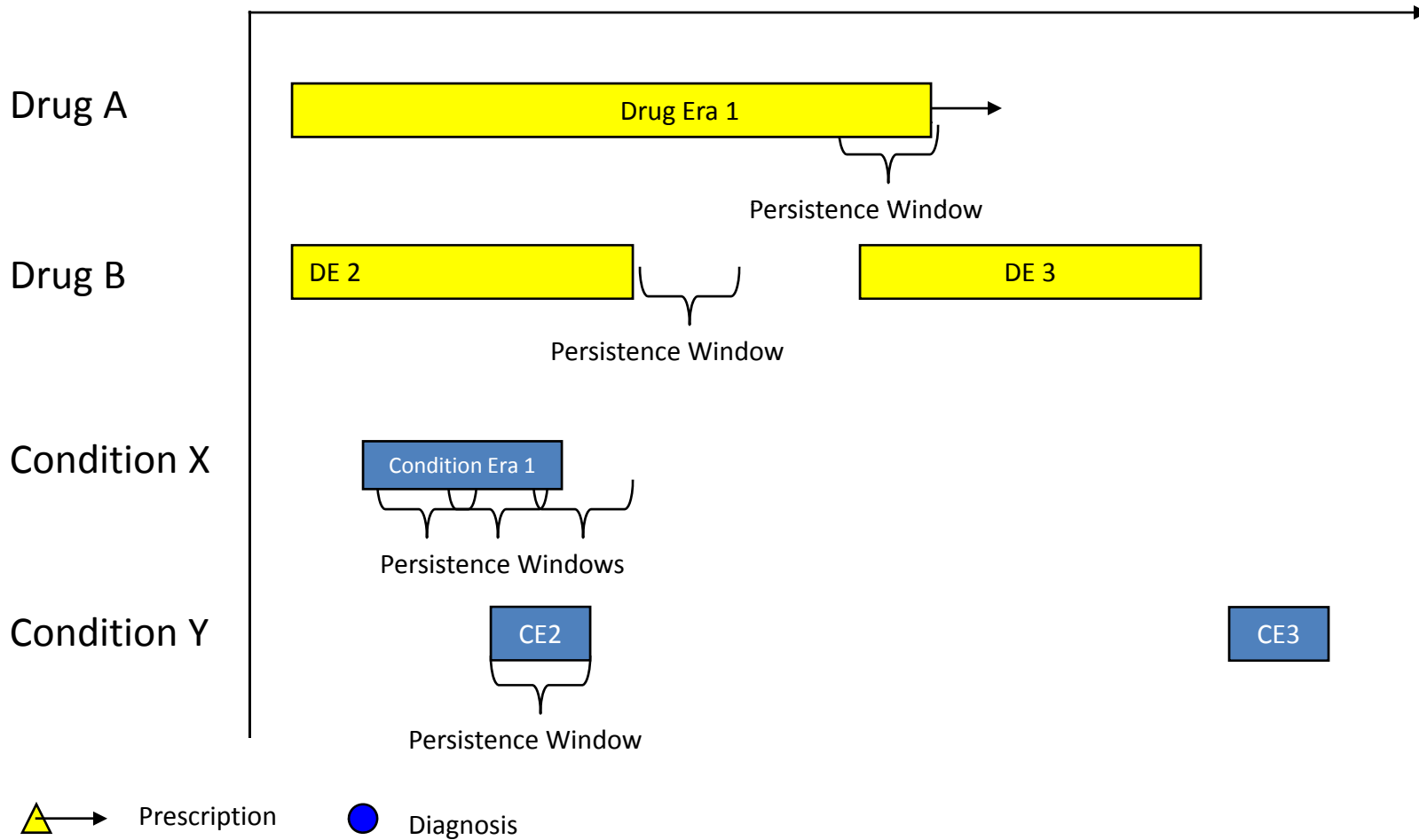

## Key principles in OMOP CDM design

A common data model should:

- **accommodate** and **distinguish** between data elements from disparate sources useful for active surveillance
  - Ex: DRUG\_EXPOSURE table is used to store elements of different types that could be useful for defining medical product exposure
    - Pharmacy Claims: Prescription dispensings
    - Medical claims: Procedural administrations
    - Electronic Health Records: Prescriptions written, medication history
- be **granular** enough to store verbatim source data but **extensible** to allow standardized approach for drawing inferences from the source data
  - Ex: DRUG\_EXPOSURE stores all prescription dispensing information (person identifier, source drug code (NDC), dispensing date, days supply, and quantity); DRUG\_ERA infers period of exposure based on available information (e.g. end date = start date + days supply)
- be **usable** to stakeholders conducting analyses
  - Ex: Methods developers need to be able to implement efficient procedures for summarizing data and estimating drug-condition associations

# OMOP Methods Library

The screenshot shows the OMOP Methods Library website. The header includes the logo for the Foundation for the National Institutes of Health and the text "Observational Medical Outcomes Partnership". The main content area is titled "OMOP Methods Library - Download Methods" and features a list of available downloads and guidelines. The list includes:

- **OMOP Methods development guidelines**
- **Disproportionality Analysis Method - OMOP Research Team**
- **Disproportionality Analysis Method specification** 7Dec 2009
- **Disproportionality Analysis Method Source Code and Examples** 2Feb 2010
- **Disproportionality Analysis Feasibility Test #1** 17Jan 2010
- **Disproportionality Analysis Feasibility Test #2** 17Jan 2010
- **Multi-Set Case-Control Estimation - OMOP Research Team**
- **Multi-set case-control Method specification** 7Dec 2009
- **Multi-set case-control Method Source Code and Examples** 2Feb 2010
- **Multi-set case-control Feasibility Test #1** 17Jan 2010
- **Multi-set case-control Feasibility Test #2** 17Jan 2010
- **Bayesian Logistic Regression - OMOP Research Team**
- **Bayesian logistic regression specification** 2Feb 2010

- Standardized procedures are being developed to analyze *any* drug and *any* condition
- All programs being made publicly available to promote transparency and consistency in research
- Methods will be evaluated in OMOP research against specific test case drugs and Health Outcomes of Interest

OMOP Methods Library at: <http://omop.fnih.org/MethodsLibrary>

# Validation throughout active surveillance

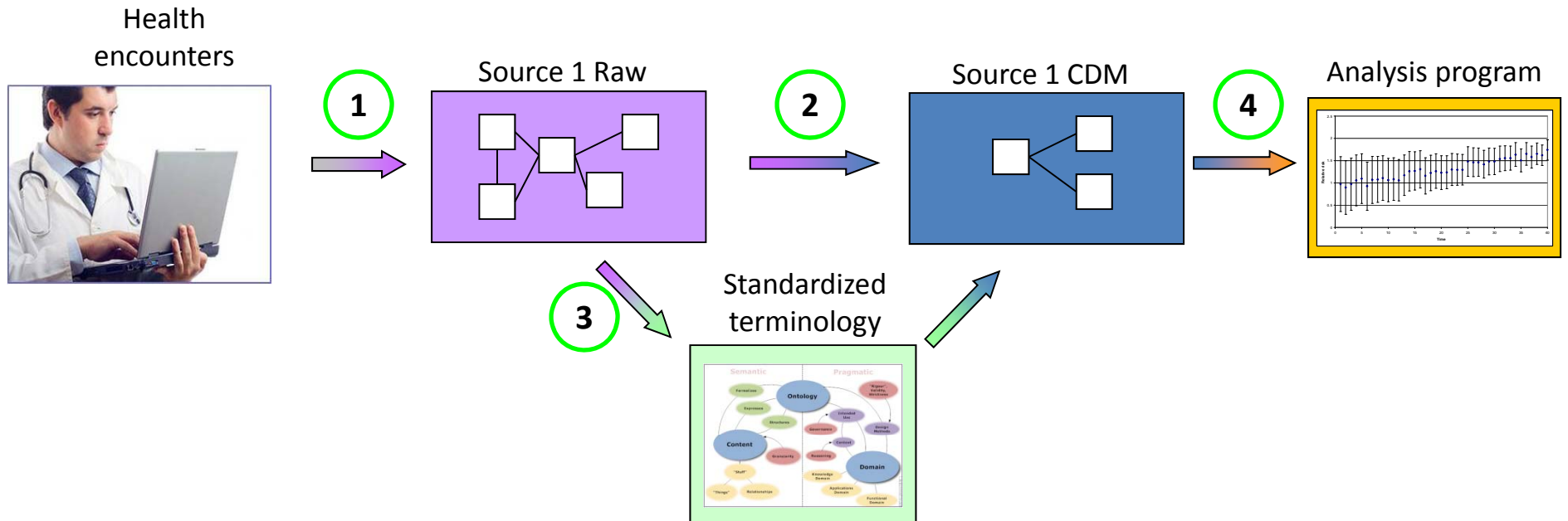

Goal: Establish a reproducible process that provides consistent and reliable analysis results to meaningfully inform drug safety monitoring

# Conclusions

- OMOP CDM successfully applied across OMOP data community
  - Accommodating disparate data sources (claims and EHR) from various data holders (payers, healthcare organizations, data aggregators, resource organizations)
- Methods and tools have been developed to enable drug safety research across a network of disparate data sources
- Common data model can enable a transparent, reproducible process for active surveillance analyses
- Outstanding need to establish a validated standard that can be truly ‘common’ for all stakeholders

OBSERVATIONAL  
MEDICAL  
OUTCOMES  
PARTNERSHIP

FOUNDATION  
FOR THE  
National Institutes of Health

Thank you

<http://omop.fnih.org>